

BIO FREEDOM

Everything You Need to Know About

Beekeeping



Table of Contents

I. Introduction.....	3
Why Beekeeping.....	3
Before You Begin.....	5
Precautions.....	6
Location.....	7
II. Life Inside the Hive.....	9
Eggs.....	9
The Queen.....	11
The Workers	13
The Drones.....	16
III. Seasonal Activity of Bees.....	18

Spring.....	18
Summer.....	19
Fall	19
Winter.....	20
IV. Bee Diseases.....	24
American Foulbrood.....	24
European Foulbrood.....	25
Varroa.....	26
V. Beekeeping Tools.....	26
Beekeeper Suit.....	27
Smoker.....	29
Choosing the Bees.....	31
Hives.....	33
VI. How to Build a Hive.....	38

Hive Components.....	39
Tools.....	46
Materials.....	49
Cutting the Board.....	51
Assembling the Parts.....	53
The Stand.....	54
The Bottom Board.....	58
The Deep-Hive Bodies.....	65
The Frames.....	67
The Inner Cover.....	83
The Telescopic Outer Cover.....	91
Assembling the Hive.....	94
Adding Feeders to Your Hive.....	96

How to Build Your Own Hive-Top Feeder.....	101
VII. Getting Started.....	108
Installing the Bees.....	110
Removing the Inner Cover of Your Beehive.....	117
Cleaning the Hive	119
Controlling the Swarm	120
VII. The Beekeeper's Seasonal Activities.....	122
Spring Activities.....	122
Summer Activities.....	123
Fall Activities.....	126
Winter Activities.....	130
VIII. FAQ.....	132
IX. Benefits of Beekeeping.....	134

I. Introduction

Why Beekeeping?

Bees and their behavior have attracted the attention of humans since at least ten thousand years ago. The oldest depiction of the use of honey dates back to 13000 B.C. Perhaps the first to succeed in raising bees in man-made hives were the old Egyptians. They were known to consider honey sacred and use it not only for the first types of deserts, but also as ointments and offerings for their dead.

In antiquity, the hives were to be found in almost every household, and honey was as important as poultry today. The natives of South America, Australia, Asia and Africa still harvest wild honey as a main occupation.

But before starting out in this domain, remember one thing: this is

not only a simple hobby, but an entirely unique lifestyle. After the first year, when you are out there among the bees and you watch them work you'll understand what I mean.



The worldwide request for honey and honey products is continuously rising, yet the costs remain low. The source material costs nothing. The bees handle that alone. The consumption of honey is still increasing, and small wonder to that, if we think about the miraculous benefits of honey products and the increasingly unhealthy lifestyle our society keeps plunging in. It is already a cliché that you don't have a lot of options when it comes to healthy food, but honey has been around for millennia and it's almost ready-

made, you only need to have bees and harvest the goods. With beekeeping the profits can reach \$ 10 000 every month.

Before You Begin

No teacher is better than experience, and you will learn a lot no doubt, but it is important to prevent certain mistakes for the sake of the bees' wellbeing. Here are a few things you need to know before you begin, as well as tips for a good start.

First of all, beekeeping is such a complex activity, one could say it is like an art. One lifetime is simply not enough to know everything about bees and beekeeping. However, it is neither difficult nor time consuming. It's actually quite fun and relaxing. You will learn something new with every season, and this is one other reason to start as quick as possible. Many wait until their retirement, but I recommend you to start now.

This is a beginner's book, meant to introduce anyone into the first steps of beekeeping. Make use of all the mediums accessible to you, such as specialty magazines, internet forums or, if you have any beekeeping communities in your vicinity, don't hesitate to join!

Precautions



Before becoming a beekeeper, remember that bees sting - and don't think you or your family will be spared just because you are their caretaker. For all they know,

you're just another intruder in their household. For most people, the bee sting poses no danger, causing light or intense pain, depending on the individual. For about 0.4 % of the world's population, however, a simple sting can lead to anaphylaxis and subsequently death. It is normal to see a swell on the stung zone, but if it gets too

big, or the person suffers severe itching or cannot breathe, you should worry. Comfort reasons are enough though to keep your bees away from neighbors.

Location

Before building or ordering your hives you should think about a good place to put them.

Technically, the hives can be placed anywhere: in a



garden or a yard, on a porch or by the back door, both in the country and in the city (but always make sure you don't bother neighbors or passing people), on a rooftop. You don't need to have meadows or flowers close by: the bees will find their way. Of course, space and access are preferable, as is a water source in the proximity,

moderate wind and sunlight. Avoid full sun contact with the hive, as it makes ventilation hard, but also avoid shades, as it might create mold. If you get strong winds in your area it is a good idea to protect the back of the hive from them. Either place the hive with the back at trees or put a face behind it. Avoid hill tops if you live in harsh winter areas, but make sure the hive is well ventilated. Don't worry if meeting all these ideal criteria is impossible; just try to fulfill as many as you can.

If you want to move your hive, consider the distance. Unless you move it a few miles, bees tend to return to the same work field. If you want to move it short distances, do it gradually, by moving the hive a few yards at a time, to let the bees accommodate to the new topography. Otherwise they will make home in the old spot.

II. Life inside the Hive

Eggs



The life of all bees starts with the egg state. Three days after it was laid, an egg hatches into a larva. The larva is being fed royal jelly for three days, after which it feeds on honey and pollen for six days. If the larva was elected by the bees to become a queen it is being fed only royal jelly. In fact, the queen eats only royal jelly its whole lifetime. The royal jelly is a substance secreted by bees and it composes of water, crude protein and small amounts of amino acids, enzymes and minerals. It is a better nourishment than honey, and it also contains royalactin, a component that causes a bee to develop

into a queen.

After about 8-10 days, the larva becomes a pupa, the next stage of development. During its 14 days as a pupa, sealed in a capped cell, it grows into a worker (female) bee, emerging on the 20th day. In most species of honey bees, workers do everything but lay eggs and mate, though some species have emergency exceptions.

Bees build honeycombs from wax extruded from glands under their abdomen. Wax combs serve as storage for honey, which is what bees eat, and also as storage for eggs and larvae.

The Queen



The social structure of the bee hive starts with the queen bee on top of the hierarchy. The queen has a lifespan of 3-5 years on average, with the oldest queen to ever live reaching 8 years old. The only purpose of the queen and its only activity for its whole lifetime is laying eggs. This ensures maintaining the colony population to around 25000 to 30000 bees. Almost 95% of all its children is what we call worker bees - the bees that create honey.

When the bees decide they need a new queen (because, for example, the fertility is dimming), they feed a new larva on royal jelly alone. As a result, it develops into a sexually mature female bee. She is fed only royal jelly for the rest of her life. Shortly after birth, the queen flies out of the hive for the mating ritual called "nuptial flight", during which she mates with 7 up to 17 different masculine bees, named drones. It happens only once in her lifetime and this is enough, because during this short period of 15 minutes or so, the queen bees receives up to 6 million spermatozoids, stacked in a special organ that only the queen possesses, named spermatheca. After returning to the hive, she starts laying eggs using the cells in the spermatheca, according to the needs of the family. The queen is genetically enhanced to lay eggs and do nothing else, thus its body and metabolism are very different. It is considerably larger than regular bees. Should the queen bee fail to fulfill her nuptial flight due to bad weather or other causes in the 6-10 days window in which she is able to do so, she will remain unfertilized and be able to lay

only drone eggs. This usually marks the death of a family, as the bees have no female larvae from which to raise another queen or worker bees. Female larvae are laid only by a fertilized queen. The queen is the most important member of the hive, and is perceived so by the bees, as it ensures the perpetuation of the species, being the only fertile bee in the hive. Her stinger is not barbed, therefore she can sting multiple times without dying.

The Workers



Worker bees make up the majority of the hive population and are all females. However, they cannot breed. The high specialized work division in the hive has created a genetic discrepancy in order to maximize the abilities of each "department". As the queen is genetically built for the sole purpose of laying eggs, and to maximize that ability it does not make honey, so the worker bees have the ovaries dormant, to maximize the productivity in their field. This may sound a bit like genetic engineering, and is not far from that, only in a natural way. What makes the huge difference? The royal jelly.



Worker bees take care of the queen and the hive and fulfill all necessary tasks to sustain the family. Their lifespan is short: 30 to 45 days during summer and a few months in winter and they pass through different stages of development. The main cause of death for a working bee is fatigue. Their muscles and wings can only take a limited amount of flight, usually around 500 miles. When they reach the limit they are simply unable to fly and look after them. During winter they don't fly at all, as we will see in a next chapter.

Regarding their role they can classify in: nurse bees, house bees or gathering bees. The nurse bees feed the larvae and the queen. The cleaning bees clean the hive and maintain the proper temperature. The gathering bees gather pollen, nectar, propolis and water. However, this work division is done according to age. The worker bee starts its life cycle by simply cleaning the wax cell in which it was born, because the cell will be reused, and if the queen inspects

the cell and it is not clean enough, the worker bee must repeat the process. After that, it fulfills the role of a nurse bee for 3 to 11 days: it feeds the larvae and queen royal jelly. After that, it deals with wax production and patching up the hive for up to one week, after which finally it becomes a gatherer bee. The worker bees have a barbed stinger, which makes it impossible for them to retract after stinging. When they fly away their abdomen tears apart and they die shortly after. Any bee will avoid stinging, and will only do so when she feels serious threat.

The Drones



Drones are the male bees. They are born from unfertilized eggs, which can be placed by worker bees as well. Although very little in number compared to the workers, their role is no less important: mating with the queen. Drones live short lives, about 25 days, because after mating their abdomen explodes. They do nothing else, except flap the wings to aid in the hive's ventilation, but if the resources are limited, they are banished from the hive or simply killed. Before winter they are banished regardless of the resources.

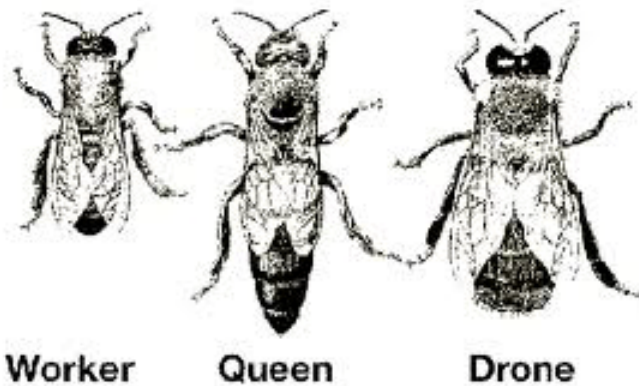

III. Seasonal Activity of Bees

Spring



As the days grow longer and warmer, the bees will take the opportunity to go out on cleansing flights to eliminate the feces. The queen starts laying eggs progressively. There are

only females in the hive, as the drones are banished during winter.

As weather gets warmer and flowers blossom, the hive comes back to life and starts gathering nectar and pollen. Drones begin to appear and the family grows bigger. If the hive has a virgin queen, she will mate, and replace the existing queen if she is too old, or simply fly away to settle a new swarm.

Summer



The hive reaches its activity peak and the queen reaches her egg-laying peak.

Fall



Population and egg-laying are diminishing. Drones begin to disappear. Activity slows down and bees get ready for the winter, eventually huddling into a cluster

as the weather gets cold.

Winter



One of the most interesting things about bees is the way they survive the winter. Like many insects, bees are exothermic, meaning that they have

cold blood and they get body heat from outer sources. They do not hibernate in the proper sense of the word, but they isolate themselves inside the hive. When temperature drops below 50 degrees they don't exit the hive anymore, with a very few exceptions. Instead, they start forming what we call a winter cluster. The cluster is the tight group of all the bees in a hive with the queen at its center. During winter they unite their efforts to keep a livable temperature inside the hive. To this end, they flap their wings or move their wing muscles and get tighter when need be in the cluster, constantly alternating places between center and the

margins so that all bees get to be warm.

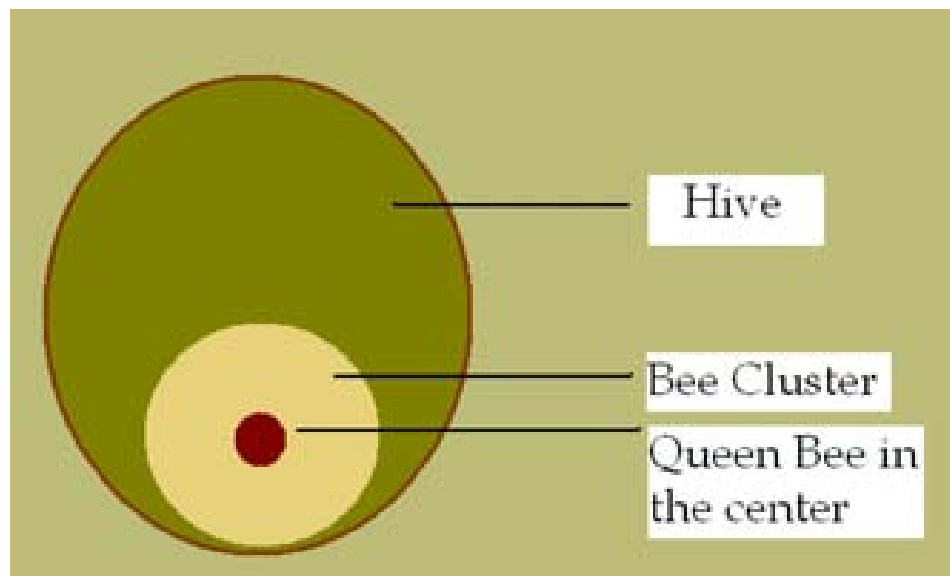

The temperature maintained is around 64-90 degrees, maybe 47-48 on the margins of the cluster. They do not sleep and they seldom defecate during winter, this being a risky operation. They never defecate inside the hive. Sometimes they hold it for the whole winter, sometimes they fly out, and if it is too cold, some never return. The bees must feed and metabolize in order to be able to create heat. The cluster moves as a whole inside the hive to get to new honey cells. It starts in the middle of the lowermost chamber and moves up and sideways. The heat is produced by the oxidation

of the honey, and it is spread in the hive by the wing flaps. This activity continues throughout the entire winter during which the honey eat up to 30 pounds of honey.

The outer layer of the cluster acts as a tampon for the inner layer. That is why they keep moving and switching places. However, if the temperature of the outer layer drops beneath 46 degrees, the bees may not be able to use their muscles efficiently anymore and they simply chill and die.

To this end, winter bees are different than summer bees, because they serve different ends and need different abilities. A winter bee is produced at the end of the summer. Its physiology differs from that of the summer bee in that it has a different blood protein. It also has a fatter body to help resist through the winter. The main difference though is that the winter bee lives much longer, 4-6 months, while

the summer bee only about 45 days. The purpose of the winter bee is just to ensure the survival of the cluster throughout winter.

Ventilation is also important during winter. The heat generated results in carbon dioxide and water vapors. The carbon dioxide remains in the lower section, being heavy, and can exit the front entrance, but the vapors go up and when they meet the cold roof or walls surfaces, they become water, which drops onto the bees. If it's too cold, it can turn to ice and kill them or - give them a cold. Not to mention altering the honey and the heat created by the cluster. Therefore, proper ventilation is necessary.

No drone gets to stay in the hive during winter.

IV. Bee Diseases

Like any other creature, bees are vulnerable to disease. A beekeeper must know and identify them in time to be able to cure them. The most frequent diseases are American Foulbrood and European Foulbrood.

American Foulbrood



This disease is pretty hard to identify by the beekeeper and many of them don't know what's going on when a foulbrood epidemic ensues. If the beekeeper doesn't do anything about the infected individuals, the latter will spread the disease to the healthy ones

as well. The most important thing is to recognize the symptoms and differentiating between a healthy and a sickly larva. Symptoms

include: larvae color darkens and they die after capping; the cappings sink inward and they often have holes in them and the cappings have a moist texture.

The good news is that this disease is not as widespread as they used to be.

European Foulbrood

European Foulbrood is a similar disease, but the larvae die before capping and they have a corkscrew shape. The brood pattern of cappings is also randomized.

Varroa



Another common disease is Varroa, which is a parasitic disease. This is not a problem for a strong hive, however, and if you use a screened bottom

board the risks are reduced. It is very important to know the life cycle of your bees to know which treatment to apply and carefully monitor them afterwards.

V. Beekeeping Tools

There are many accessories for beekeeping, some more useful and/or expensive than others. The tendency, especially after you start to get into it, is to buy as many as possible. But for a beginner, there is no point in purchasing sophisticated items that are seldom used. Here are the most important items that you need in order to

start beekeeping:

Beekeeper Suit



The best shield against stings is, no doubt, knowledge about the bees' behavior. Many advanced beekeepers end up working without any kind of protection, but that is dangerous and not recommended for a novice. So until you earn that knowledge, the most important piece of a beekeeper's gear is the suit. Don't get courageous where it's not the case - as mentioned, experience will come in time. You wouldn't want bee stings on your face - it's the breath that attracts them the most. For beginners, any suit would do, but it's preferable that it has pockets on the front. It should also have elastic sleeves

and a hat with netted veil that are detachable. A sting on the face can lead to much more pain and swelling than a sting elsewhere, while a sting on a bare hand can usually be quickly removed by fingernail scraping to shrink the amount of venom injected.

● *Tips:*

- Make sure the pants are well tucked into your socks to prevent bees from entering.
- Rubber gloves are good enough, but no type of gloves offer 100% protection against stings. Besides, gloves make a beekeeper's actions very clumsy and eventually, you will learn to work without them. But for starters, keep them on.
- The protective clothing should be generally light colored (but not colorful) and of a smooth material. This provides the maximum differentiation from the colony's natural predators, which tend to be dark-colored and furry.

- Stings retained in clothing fabric continue to pump out an alarm pheromone that attracts aggressive action and further stinging attacks. Washing suits regularly and rinsing gloved hands in vinegar minimizes attraction.

Smoker



Smoke is the beekeeper's third line of defense, after knowledge and the suit. Smoke calms the bees, so most beekeepers use a smoker, which is a tool that releases smoke from the partial burning of

several fuels. The smoke acts as a fire alarm: the bees prepare for hive evacuation due to a potential fire by feeding themselves. The smoke also neutralizes the pheromones released by guardian bees, resulting in a mass confusion. This allows the beekeeper to work around an open hive without a reaction from the bees. Additionally, when the bee is sated with honey, it is more difficult for it to flex the abdomen and sting.

Many types of fuel can be used in a smoker as long as it remains natural. Here are just a few examples: burlap, hessian, corrugated cardboard, twine, pine needles, rotten wood. Some beekeeping supply sources also sell commercial fuels like pulped paper and compressed cotton, or even aerosol cans of smoke. Some beekeepers are using "liquid smoke" as a cheaper and safer method. It is a water-based solution that is sprayed onto the bees from a spray recipient.



If you intend to raise bees just for yourself, there is no need to acquire more sophisticated material. Bee feeders are useful though, because you need to feed the bees during spring.

Any beekeeper must know the basics about bees and their life spans. This helps understand the problems they confront with and to know when they are about to swarm, when they are sick and so on.

Choosing the Bees

The box type and size create the hottest topics among beekeepers.

But don't worry, the choice is simpler: prolific bees need more space

than the less prolific ones. Don't think that the queen's breeding capacity is proportional to the number of bees in the family or the honey quantity produced. *Apis Mellifera Ligustica* is the



American bee, most widespread, prolific and gentle bee for making honey and beekeeping. Two families of bees are enough to start with (on 3-5 frames). Raising the number of families is being done gradually, as experience increases. No point in getting 40 families which will die overwinter because of your lack of experience. However, to start on the right foot it is important that you get a strong family, meaning numerous. That makes it easy to work with. During summer, a family may reach 75000 members. Most importantly, make sure they are healthy. It is best to go "shopping" in the companion of an experienced beekeeper.

Hives



Bees naturally build their shelter in tree hollows, cliff cracks, poles, bridges or other places safe from precipitation. Man has always tried to bring bees in the proximity of his lodging, in order to benefit from the valuable natural honey products, especially wax and honey. The first hives were hollow logs with fixated combs, but in the nineteenth century the modern beekeeping emerged, with man-made hives and mobile frames which can be put back and the bees are not killed for their honey, and their environment is not destroyed.

Most hives are built out of pine wood and this is the material that is recommended. You can use a different type of wood, but avoid low

quality. As of late, alternative materials have emerged, such as polystyrene. You should think which one is more suited for you.

A hive is composed of the following parts, regardless of the type: stand, bottom board, super and cover. There are other optional and additional parts, but that depends on the type of hive you want and the size of the bee yard.

The most used types of hives are:

- The Horizontal Hive



- The Vertical Hive



- The Multi-Leveled Hive



Regardless of the type, the hive must fulfill the following conditions:

- to protect the colony from rain, wind, moisture and heat;
- to be large enough for the family to develop in, but also to allow the removal and addition of frames, according to the family size;
- to be light enough to carry from one location to another;
- to allow inspection without bothering the bees' activity;
- to have standard dimensions in order to use specialized purchased materials and also to move them from one hive to another;
- to be built from a hard material (wood) to protect against mechanical shock and mice.

As a rule of thumb, if you want to have your own bee yard, it is important that your hives are the same type and size and same frame type, as you will change frames in between hives.

The best type of hive is by far the multi-leveled hive. It eases the beekeeper's work a whole lot - you work with the hive body, not with the frames. Its volume can be extended according to your needs by simply adding levels. This hive is also adapted to the newest methods of beekeeping. Initially it is made out of three bodies, identical in dimension that lay one on top of the other, each one of them usually having ten frames.

The hive entrance must face either South, South-East or South-West. Make sure it's not facing a path, or you risk creating collateral damage. The hives must be maintained, looked after and cleaned periodically. Think at the hive as just another one of the beekeeper's tools. Bees don't care where they work and live. They do the same fine job inside a box as they do inside a tree.

It is recommended that you build at least one hive, so you

understand how they are built and what is going on inside them. If you know a thing or two about carpentry you will build frames and boxes easily. You can also order the parts and assemble the hive yourself, or you can simply order the hives directly. In the following chapter we describe the building process step by step with materials, measurements and everything you need to know to assemble your own multileveled hive. To be honest, I see this as part of the fun of being a beekeeper.

VI. How to Build a Hive

The multilevel hive is conceived after Langstroth and Rooth model and is a high-capacity vertical hive. Basically, during harvesting, the volume can be extended by adding additional bodies above. Though it requires a certain manipulation experience, this type of hive is the most mobile, allowing the use of the newest and most efficient methods of beekeeping. It also offers the bees conditions close to the

natural environment (tree hollows), the hive spreading vertically.

Hive Components

- Stand (*optional*) - the stand plays an important role in keeping your hive away from rot and moisture. The best material for it is the cypress wood.



- Bottom Board - this is the floor of the hive. Cypress is again recommended. If you think your hive could use some extra ventilation, you can use a screened board.



- The Bodies - usually three pieces; there are two kinds of hive bodies: supers - normal activity hive bodies and brood chambers, where queen bees lay their eggs. Usually the multileveled hive has one brood chamber and two deep-hive bodies or supers: one for the bees to store their honey, and one for your honey. If needed, you can add more on top. The supers are added two months after you get your family, or in the spring.



- Queen Excluder (*optional*) - the queen excluder is a screened piece of metal framed in wood with the holes 0.163 inches wide, just enough for worker bees to pass through, but not for the queen and the drones. It is used to segregate the queen inside the brood chamber, to prevent her from laying eggs in the honey storage supers.



- Frames - frames are used as a skeleton for the honeycombs. If honey bees build the combs in moveable frames, the beekeeper can remove them and put them back easily. They look like a usual window frame and normally a deep hive body contains ten, while a super contains nine.



- Inner Cover - the inner cover is an optional part, but highly recommended. It provides extra ventilation and keeps a body of air on the upper side of the hive as a tampon between the cold air outside and the heat inside. It also prevents the bees from attaching the outer cover to the bodies and makes it easier to operate the hive. Last but not least, it allows the beekeeper to easily feed the bees in time of need. It is in the shape of a tray with a hole in the middle, for bee's access.



- Outer Telescopic Cover - this is the real hive roof, the one that actually protects against rain and snow. It's not necessarily made of metal, but that may help against storms. Always have something on the outer cover to make sure an eventual storm won't take it off and kill your bee family. Ventilation is very important, as this is the part where condensation may form. The best material for the outer cover is, as in the stand's case, the cypress.



Tools

TAPE MEASURE



TABLE SAW



or:

HAND SAW



HAMMER



COMBINATION SQUARE OR PITCH SQUARE





HAND PLANE



UTILITY KNIFE



LEVELS



Materials

Like we mentioned before, the most popular type of hive is the Langstroth multileveled hive. It's been around for decades and most suppliers offer the ten-frame version of it. It is the same version we teach to build here, but the building methods is identical for the 8 frame hive as well. More frames means more honey, but less frames make your hive easier to transport, so it depends on you and your needs what type of hive you want to build. If you want to start out a beekeeping and honey harvesting business and you want to fill your

yard with hives, it is probably better to have smaller hives. But for beginners, we feel that this hive is the most appropriate.

The measurements of the Langstroth hives are 22 x 18 x 29-1/4 inches for the ten-frame version and 22 x 15-3/4 x 29-1/4 inches for the eight-frame version. Since you can add honey supers according to your needs, the capacity is virtually unlimited.

Due to the popularity of the hive model, you can always easily find tools and replacement parts, including frames. The costs are a real steal compared to the benefits. You can build your hive with purchased materials with about \$160. You can always find recycled wood though, which will keep the costs to a minimum.

The best types of wood for hive building revolve around pine, cedar and cypress. The pine wood is cheap (knotty wood even cheaper, but not as smooth) and ideal for the bodies, while cypress and cedar are recommended for the top and the bottom covers and stands, due to resistance to mold and humidity.

Cutting the Boards

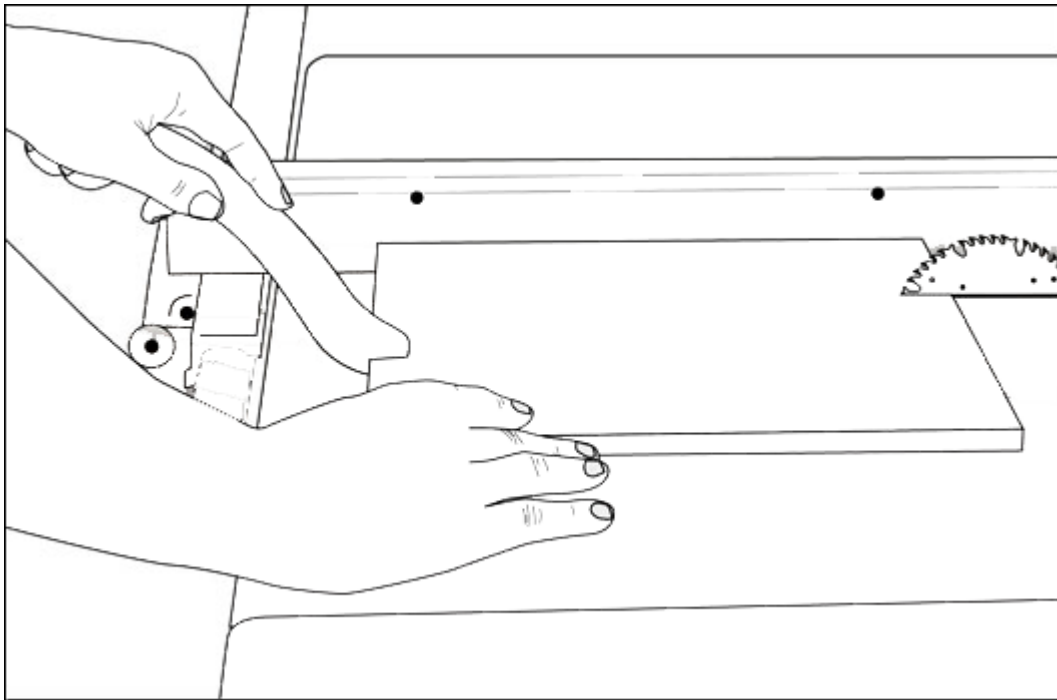

The easiest and most efficient way is to use a fixated table saw.



Be very careful, though, this can be dangerous.

Fit the saw blade so that it cuts all the thickness of the wood, but not too much over it. If the blade rises too much above the thickness the cut won't be that smooth. With the lumber prepared on the table, start the saw and let it spin a bit to get to its full rotation speed. When you cut a board, remember to count the little portion cut by the saw. Cut the wood with steady, smooth and long moves. Do not rush and don't use your force to push, you may injure yourself. All you need to do is drive the wood in the blade's way. Always use both your hands and keep a distance from the saw.

I highly recommend using a push stick (shown in the picture above) for safety. You can always buy one, but you can also make it.

Assembling the Parts

Whether you're buying the parts of the hive or build them yourself, you will have to bring them together. Some beekeepers use glue in addition to screws and nails. Others believe that glue emissions are toxic for the bees over time. I don't use glue in my hives, but if you want a sturdy hive or if you live in an area where winters are harsh you might consider it. If you must use glue, clean the wood before applying it. Move quickly, as it will harden fast. All the following instructions show the types of screws or nails needed, but don't specify gluing each joint. This is something you will choose on yourself.

Make sure you assemble your parts at 90 degree angles, otherwise your hive will eventually fall apart. Use a carpenter's square.

In the industry, wood is named by the dimension it had prior to being cut. The real dimensions after finish differ. Example: 1 inch x 8 inch lumber is in fact 3/4 inch x 7-3/4 inch.

The Material column in these tables lists the nominal, prior to cutting dimensions, and the Dimensions column lists the real and final measurements.

The Stand

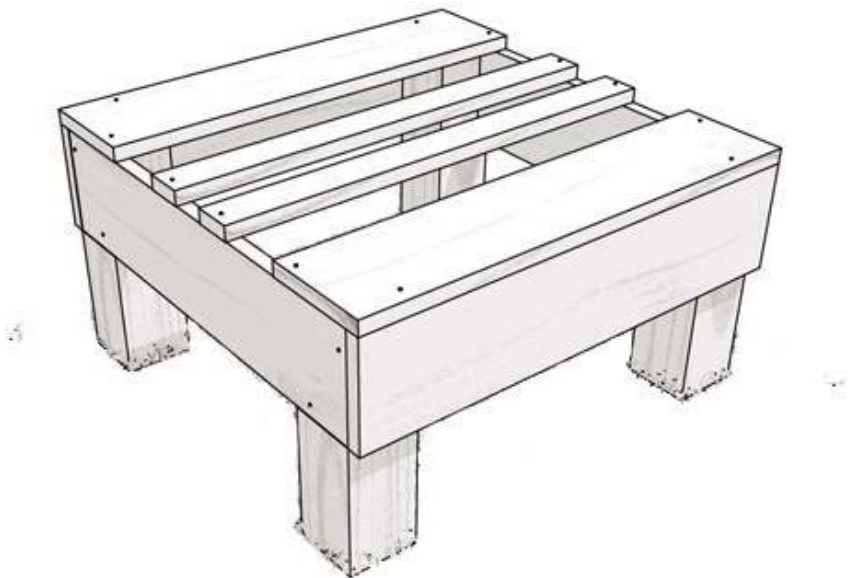

The stand is an optional part of the hive, but it is highly recommended. It prevents the floor of the hive to lie directly on the ground, thus avoiding cold or overheating, providing better ventilation, protecting against mites and mold and makes it more accessible.

For the stand is good to use cedar or cypress, even if they're a little bit more expensive, because they have a higher resistance to humidity and mold.

Lumber	Hardware	Fasteners
2, 8' lengths of 1" x 6" cedar or knotty pine lumber	Optional: weatherproof wood glue	30, #6 x 2-1/2" deck screws, galvanized, #2 Phillips drive, flat-head with coarse thread and sharp point
1, 8' length of 4" x 4" cedar posts	Optional: a pint of exterior latex or oil paint, exterior polyurethane, or marine varnish	

Quantity	Material	Dimensions	Notes
4	4" x 4" cedar posts	12-1/4" x 3-1/2" x 3-1/2"	These are the leg posts of the stand. Rabbet 5-1/2" wide by 3/4" deep along one end of the post (this rabbet accommodates the narrow sides of the stand).
4	1" x 6" of cedar or knotty pine	24" x 5-1/2" x 3/4"	These are the long sides of the stand and wide struts for the top.
2	1" x 6" of cedar or knotty pine	24" x 2" x 3/4"	These are the narrow struts for the top.
2	1" x 6" of cedar or knotty pine	22-1/2" x 5-1/2" x 3/4"	These are the short sides of the stand.

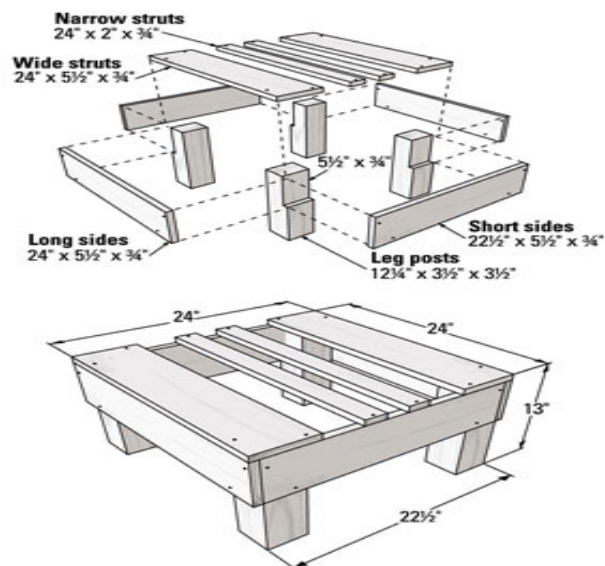

- Attach the two short sides of the stand to the leg posts and screw them into the rabbet cuts. Two screws in each post. Make sure the edge of each side rail is flush with its post.
- Attach the two long sides of the stand to the leg posts and short sides. Put a screw in the leg post and another one into the edge of the short side rail.
- Attach the wide and narrow struts to the top edges. Screw them together with four deck screws for each wide strut, going through the struts and into the top edges of the long and short sides. Center the two narrow struts between the wide ones. Put one deck screw at the end of each strut through the top edges of the sides.



The Bottom Board

The screened bottom board is the best way to keep your hive properly ventilated. Lack of ventilation can cause stress and even death and disease among your bee colony. Varroa is probably the most spread bee disease. As it is caused by Varroa mites, a double screened bottom board helps a great deal - not by preventing them from entering the hive, which is impossible, but by preventing them from returning and reattaching to the bees' body after falling off them (which happens naturally). When they don't fall to the ground through the screened board openings, they are rendered unable to move by the sticky inspection board from under the screening. You can actually see them stuck on the inspection board and get an idea about the number of mites, and, if it's the case, take measures. Materials will cost around \$20, but recycled wood is always an option. If you want extra seasonal or mold resistance go for cedar or cypress wood.

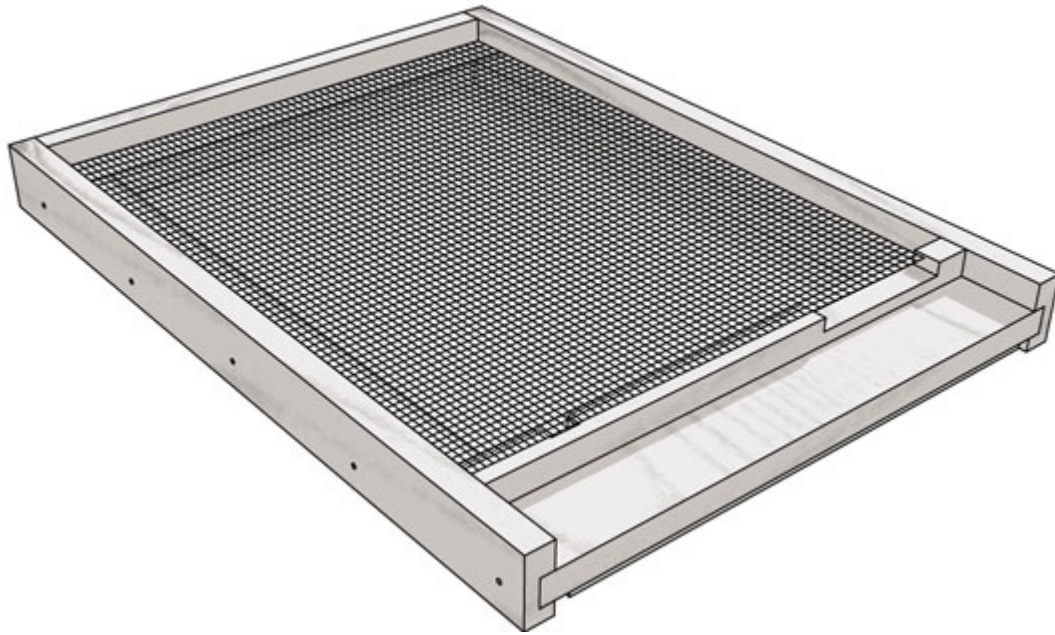

Size: 22 inches x 16-1/4 inches x 1-7/8 inches

Lumber	Hardware	Fasteners
1, 6' length of 1" x 5" knotty pine lumber	1-1/2 yards 2-ply nylon string/twine (you'll likely have to purchase a roll of this stuff)	12, #6 x 1-3/8" deck screws, galvanized, #2 Phillips drive, flat-head with coarse thread and sharp point
	1/8" (#8) hardware cloth (typically comes in 3' wide and 10' long rolls, but some beekeeping supply vendors sell	14, 5/32" x 1-1/8" flat-head, diamond-point wire nails

	it by the foot)	
	White Plasticor corrugated board (available at art supply stores in various sizes). Make sure you order a piece that will allow you to wind up with board that's 22" x 14" x 3/16"	24, 3/8" staples for use in a heavy-duty staple gun
	Optional: weatherproof wood glue	
	Optional: a pint of latex or oil exterior paint (white or any light color), exterior polyurethane, or marine varnish	

Quantity	Material	Dimensions	Notes
2	1" x 5" knotty pine	2" x 1-7/8" x 3/4"	These are the side rails. Dado 3/4" wide by 3/8" deep along the entire length.
2	1" x 5" knotty pine	16-1/4" x 2" x 3/4"	These are the long sides of the "floor."
2	1" x 5" knotty pine	14-3/4" x 3/4" x 3/4"	One piece is the rear cleat. The other piece is the entrance reducer.
1	1" x 5" knotty pine	15-1/2" x 4" x 3/4"	This is the wide front side of the "floor."

1	1" x 5" knotty pine	15-1/2" x 2" x 3/4"	This is the narrow rear side of the "floor."
1	Plasticor corrugated art board	22" x 14" x 3/16"	This is the removable inspection board.
1	#8 hardware cloth	18" x 14-1/2"	This is the screened panel that covers the opening in the floor.

Floor Assembly:

- Attach the side rails and the back cleat to the floor. Insert the floor into the cut of each side rail. Make sure the dado is facing the same way as in all the rails.

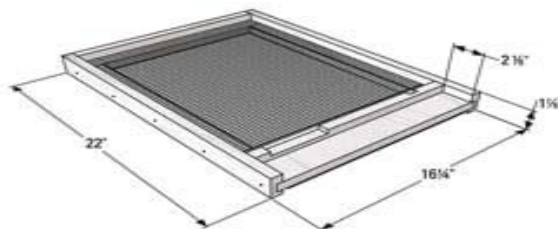
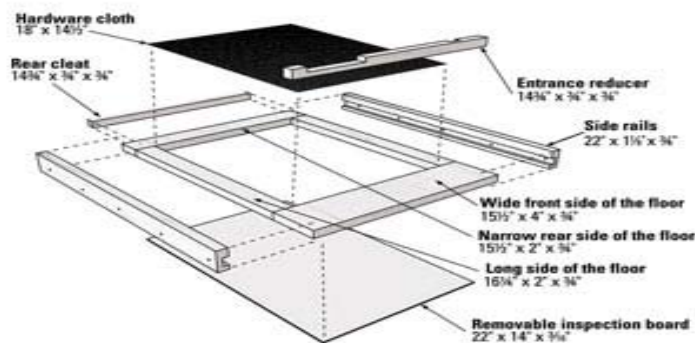

- Drive one of the deck screws halfway into the center of each side rail and into the edges of the floor assembly. Check everything before driving the screws all the way in. After that insert four more screws spacing them at equal distance of each other along the long rails.

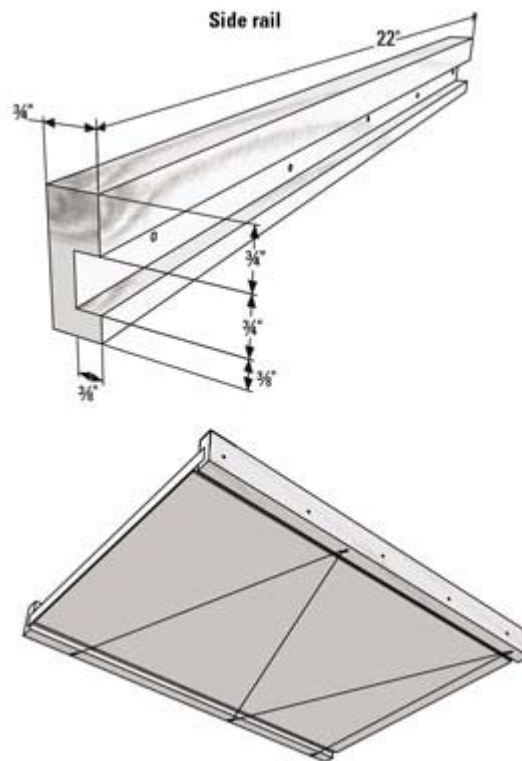

- It's always easier to insert screws if you execute a pre-drill. It's also safer, as it prevents splitting the wood. Applying glue is practically a good idea, especially in harsh winter areas, but

don't forget it's toxic for bees. If you choose to use it, pick a weatherproof type.

- Attach the rear cleat to the floor with diamond pointed wire nails. Finally, apply one more nail in each corner of the floor assembly.
- Now you can add the screening #8 hardware cloth on the top of the bottom board opening with 3/8 inch staples, 2 inches apart from each other. Continue stapling the whole screening perimeter. Leave no gaps for the bees to squeeze through.
- Add the nylon twine to the bottom of the floor assembly.
- Now staple the nylon twine to the bottom of the floor assembly in a zigzag pattern, keeping it as taut as possible. To prevent it from unfolding you can singe the ends of the twine with a flame. Slide the inspection board into the assembly.

- Turn the bottom-board right-side-up and slide the inspection board under the screened area with the twine mesh holding it in place. If you want to keep the mites from re-entering the hive, apply petroleum jelly on the top of the inspection board. They will get stuck in it after falling from bees. Clean it and reapply it with each inspection.
- Never paint the inside of your hive, as paint can be really dangerous for the bees.

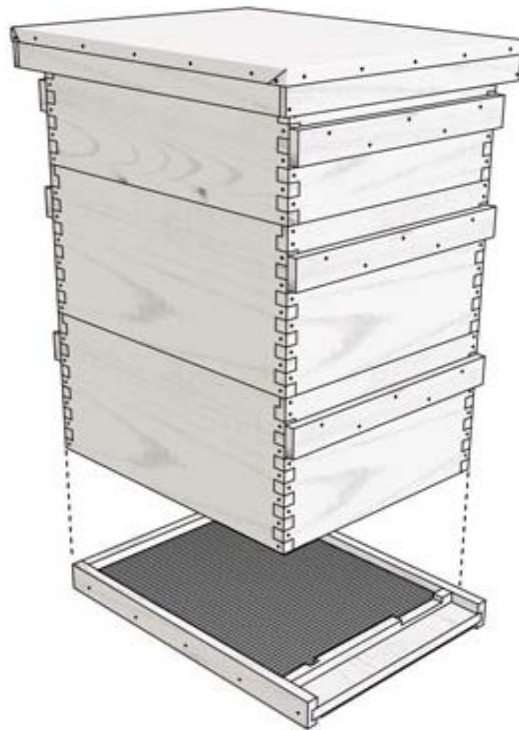

The Deep-Hive Bodies

Since the brood chamber and the honey supers are identical in matters of construction, you will be building three deep-hive bodies. One will serve as a brood chamber, one as storage for the bees' food, and the last one for you to collect the surplus honey. Should your bees produce more honey than the capacity of your hive body (or super) you can always make more super and add them on top. This is why the multileveled hive is so practical, and that is why the bodies are called supers: you can always add one on top of the other. Not to mention that you can separate the mating chamber from the winter storage.

Deep Hive Bodies (Ten-Frame Version)			
Quantity	Material	Dimensions	Notes
4	1" x 12" clear pine	19-7/8" x 9- 5/8" x 3/4"	These are the long sides. For the 3/4" finger joints, start your first cut 3/4" from the bottom. Note that the top finger is 5/8" (not 3/4") and is trimmed to 3/8" long.
4	1" x 12" clear pine	16-1/4" x 9- 5/8" x 3/4"	These are the short sides. For the 3/4" finger joints, start

			your first cut at the bottom. Note that the top finger is 1-3/8" (not 3/4"). Rabbet a cut 5/8" wide by 3/8" deep along the entire inside top length.
4	1" x 12" clear pine	16-1/4" x 1-7/8" x 3/4"	These are the hand rails.

- Start by assembling the two long sides and the two short sides by simply tapping the finger joints together. If the fit is too snug, you can remove some wood with sandpaper.
- After squaring everything up, nail the joints with galvanized 6x2 inch nails hammered into the center fingers of the hive's corners.
- Screw the hand rails and the short sides of the hive body together. The top edge of the hand rails should be positioned 2 inches down from the top edge of the hive body. Five screws per hand rails should do.

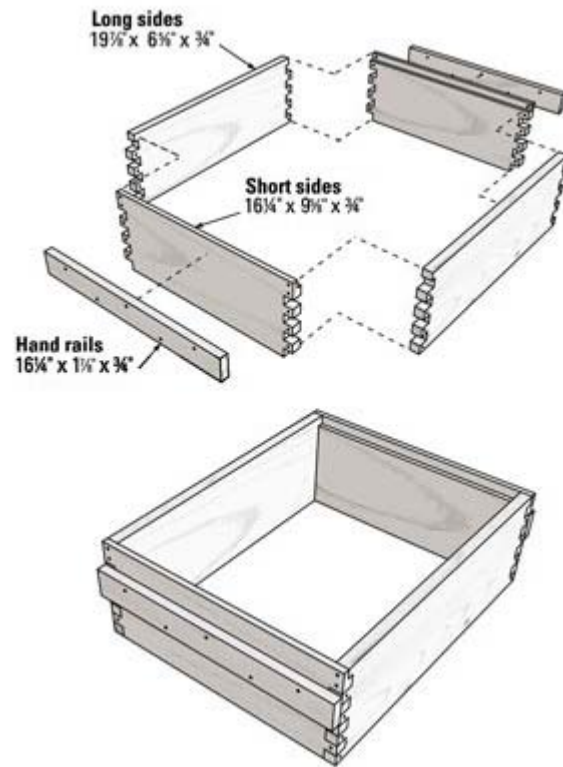

The Frames

The frames are probably the hardest part of the hive, as they require more intricate work. But they are still easy. The costs will probably gravitate around \$15, even less if you use recycled wood.

The most popular model of frames is the Langstroth model. It comes in three sizes: deep, medium and shallow, each matching the hive body size. The size difference translates only in height:

- Deep frames: 19 inches x 1-1/16 inches x 9-1/8 inches;
- Medium frames: 19 inches x 1-1/16 inches x 6-1/4 inches;
- Shallow frames: 19 inches x 1-1/16 inches x 5-3/8 inches.

Usually the deep frames are for the bees to store their brood and provisions. For harvesting honey, the medium or shallow types are used. Each deep frame can hold 6 pounds of honey, medium frames can hold 4 pounds each, and a shallow frame - 3 pounds. Regardless of the size, the cutting method is the same.

The frame comprises of:

- a top bar with a wedge;

- a bottom bar with a slit or hollow running along;
- two sidebars;

The frames hold foundation, which means they have a thin, rectangular sheet of wax embossed with a comb pattern, to encourage the bees to draw even and uniform honeycombs.

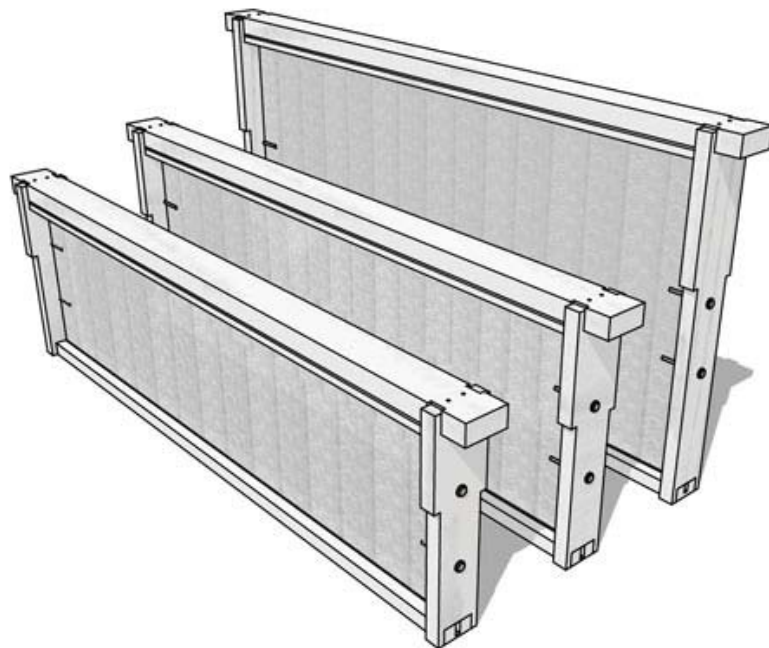

Here is what you need for 10 frames of any size (deep, medium, or shallow):

Lumber	Hardware	Fasteners
1, 4' length of 1" x 8" clear pine lumber	10, sheets of crimp-wire beeswax foundation. Select the size that corresponds to the size of frame you plan to build (deep, medium, or shallow).	65, 5/32" x 1-1/8" flat-head, diamond-point wire nails
1, 8' length of 2" x 3" spruce or fir	Optional: weatherproof wood glue	35, 5/8" finish brad nails
		45, foundation support pins

Beeswax foundation is not easy to be built - the necessary equipment is expensive. You can buy it at the beekeeping stores, or, more accessible, online; just do a search for "beekeeping supplies".

Beekeeper stores have different nomenclatures, and sometimes you might find crimp-wire foundation and sometimes hooked-wire foundation. But they are the same thing. For this design you want the kind of foundation where the vertical wires protrude from one side and bend at right angles, and the wires on the other side are trimmed flush with the foundation.

Foundation pins can only be found at the beekeeping supply vendors (you can find on the internet; you can order the pins along with the beeswax foundation).

Here are listed the frame elements and how to cut them according to the size you want:

Deep Frames			
Quantity	Material	Dimensions	Notes
20	2" x 3" spruce or fir	9-1/8" x 1-3/8" x 3/8"	These are the side bars. Drill two 1/8" holes 1-3/4" apart and centered top to bottom and left to right. These holes are for the foundation pins.
10	1" x 8" clear pine	19" x 1-1/16" x 3/4"	These are the top bars.
10	1" x 8" clear pine	17-3/4" x 3/4" x 3/8"	These are the bottom bars. Cut a saw kerf centered along the entire length,

			1/8" wide by 5/16" deep.
10	Sheets of 8-1/2" deep crimp-wire beeswax foundation		
Medium Frames			
Quantity	Material	Dimensions	Notes
20	2" x 3" spruce or fir	6-1/4" x 1-3/8" x 3/8"	These are the side bars. Drill two 1/8" holes 1-3/4" apart and centered top to bottom and left to right. These holes are for the foundation pins.
10	1" x 8" clear pine	19" x 11/16" x 3/4"	These are the top bars.

10	1" x 8" clear pine	17-3/4" x 3/4" x 3/8"	These are the bottom bars. Cut a saw kerf centered along the entire length, 1/8" wide by 5/16" deep.
10	Sheets of 5-5/8" medium crimp-wire beeswax foundation		

Shallow Frames

Quantity	Material	Dimensions	Notes
20	2" x 3" spruce or fir	5-3/8" x 1-3/8" x 3/8"	These are the side bars. Drill two 1/8" holes 1-3/4" apart and centered top to bottom and left to right. These holes are for

			the foundation pins.
10	1" x 8" clear pine	19" x 11/16" x 3/4"	These are the top bars.
10	1" x 8" clear pine	17-3/4" x 3/4" x 3/8"	These are the bottom bars. Cut a saw kerf centered along the entire length, 1/8" wide by 5/16" deep.
10	Sheets of 4-3/4" shallow crimp-wire beeswax foundation		

- The side bars are wide on one end and narrow at the other. We will call the narrow end the bottom and the wide one the top.

This is the ideal shape that respects bees' movement without them getting glued.

- On each end there is a notch. Cutting the side bars is the same for all three dimensions (deep, medium and shallow). Follow these steps to cut your side bars:

1. Remove $\frac{3}{16}$ inch of material from each vertical edge of the bar to create the taper.
2. Cut a notch $\frac{7}{8}$ inch wide by $\frac{7}{16}$ inch deep at the top of the bar. The top bar will fit into this notch when you assemble the frame.
3. Cut a notch $\frac{3}{4}$ inch wide by $\frac{3}{8}$ inch deep at the bottom of the bar. The bottom bar will fit into this notch when you assemble the frame.

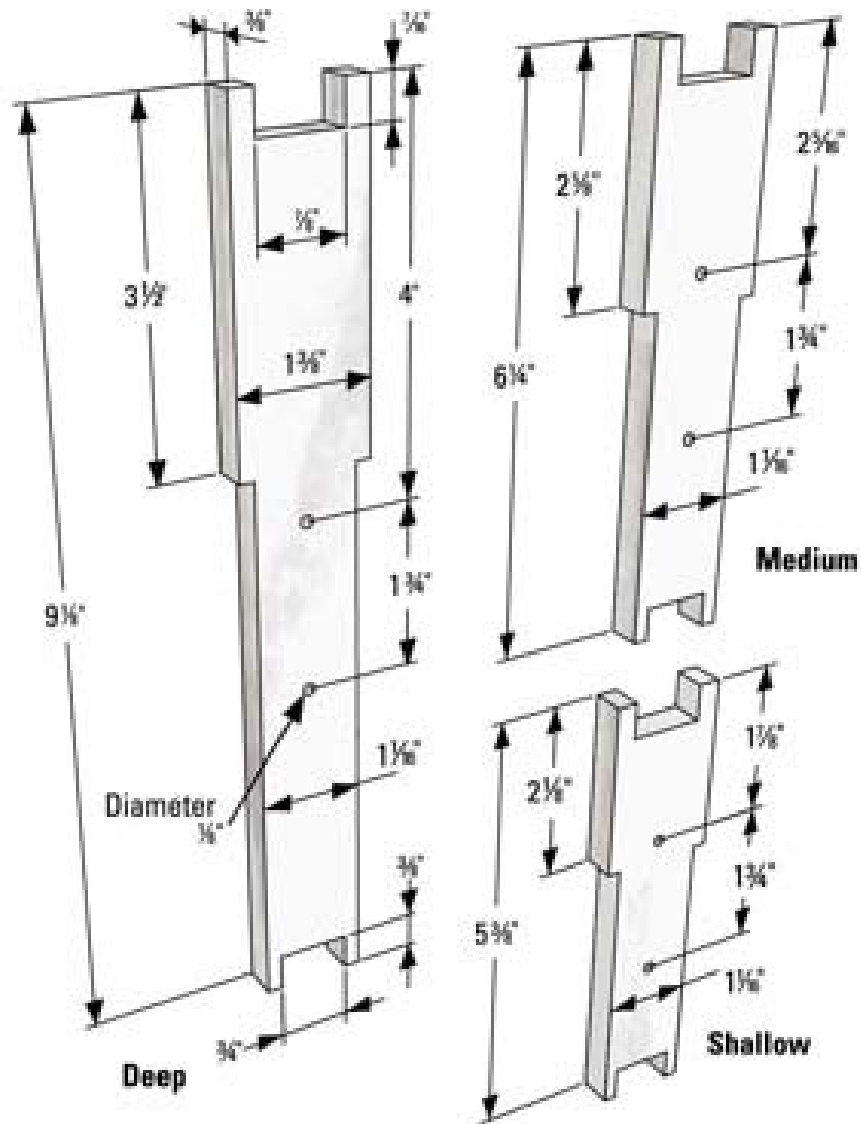

- The hardest and trickiest part is cutting the top bars. I don't want to scare you, just to make sure you are extra careful.

1. Cut a kerf $\frac{1}{8}$ inch wide by $\frac{5}{16}$ inch deep along the length of the underside of the top bar.
2. Cut a vertical notch $\frac{3}{8}$ inch wide by $\frac{3}{32}$ inch deep on both sides and at each end of the top bar. The notch starts $\frac{5}{8}$ inch back from the ends of the bar. When you assemble the frames, you insert the top of the side bars into these notches.
3. On the underside of each end of the bar, make a 1 inch wide by $\frac{3}{8}$ inch deep rabbet. This creates the tabs at each end of the top bar.
4. Cut a kerf $\frac{1}{8}$ inch wide by $\frac{9}{16}$ inch deep along the length of one of the vertical sides of the top bar. Position the cut $\frac{3}{8}$ inch down from the top of the bar. Don't throw away the resulting piece of wood. This will be the wedge that you will use later for the foundation.

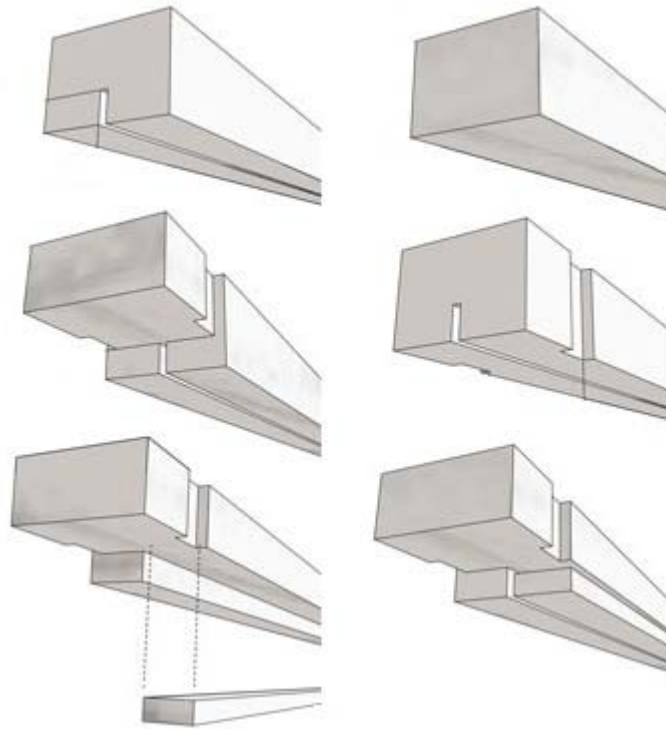

- Insert the side bars with the wide ends into the slots of the top bar. Insert the bottom bar into the slots at the narrow ends of the side bars. The kerf cut is oriented to be within the frame assembly (the kerf is used to hold the foundation in place). The frame should have a rectangle form.
- Nail the frame together with 8x 1-1/8 inch nails per frame (two for each end of the top bar and two for each end of the bottom bar).

- Again, gluing them is optional. Hold the frame on the work surface and drop the flush end of a sheet of foundation into the kerf of the bottom bar. Coax the other end (the one with the bent wires) into the space you removed the wedge bar from. Turn the frame (and foundation) upside down, top bar on the work surface. Measure the spaces and adjust, so that it is even on both ends and sides. Place the wedge strip back in its place.

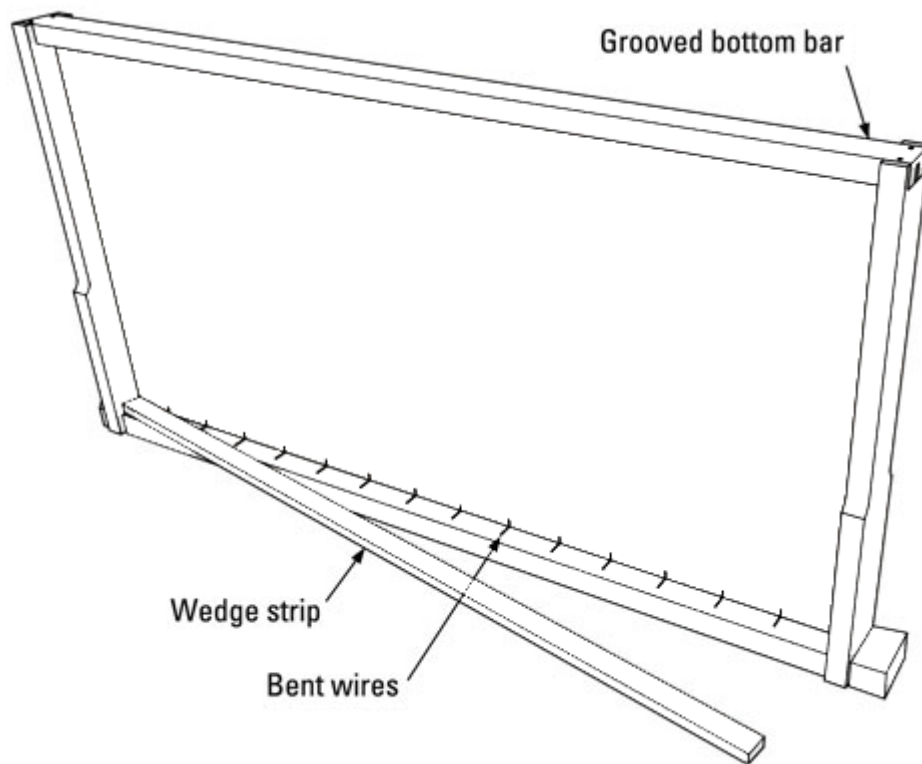

- Place the wedge removed earlier in its place. The foundation wires must be sandwiched between the top bar and the wedge. Use 5/8 inch brads to attach the wedge strip to the top bar.

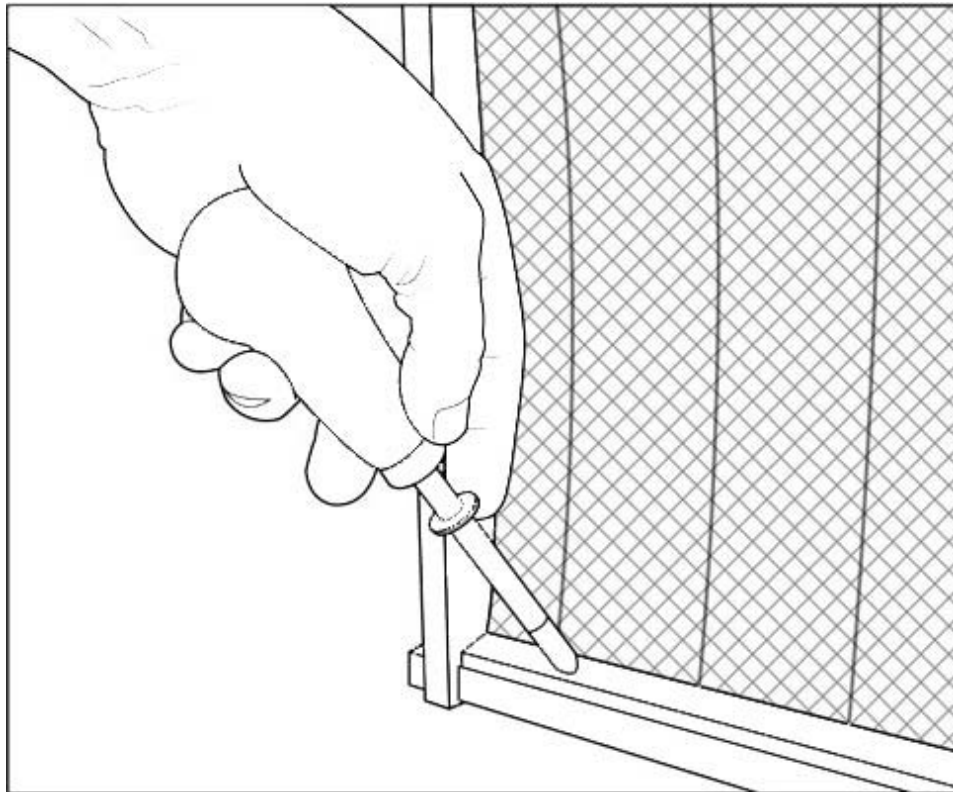

- Start with one brad in the center and then add one brad at each end of the wedge strip. Three should do. Also, do not use glue on the wedge strip.

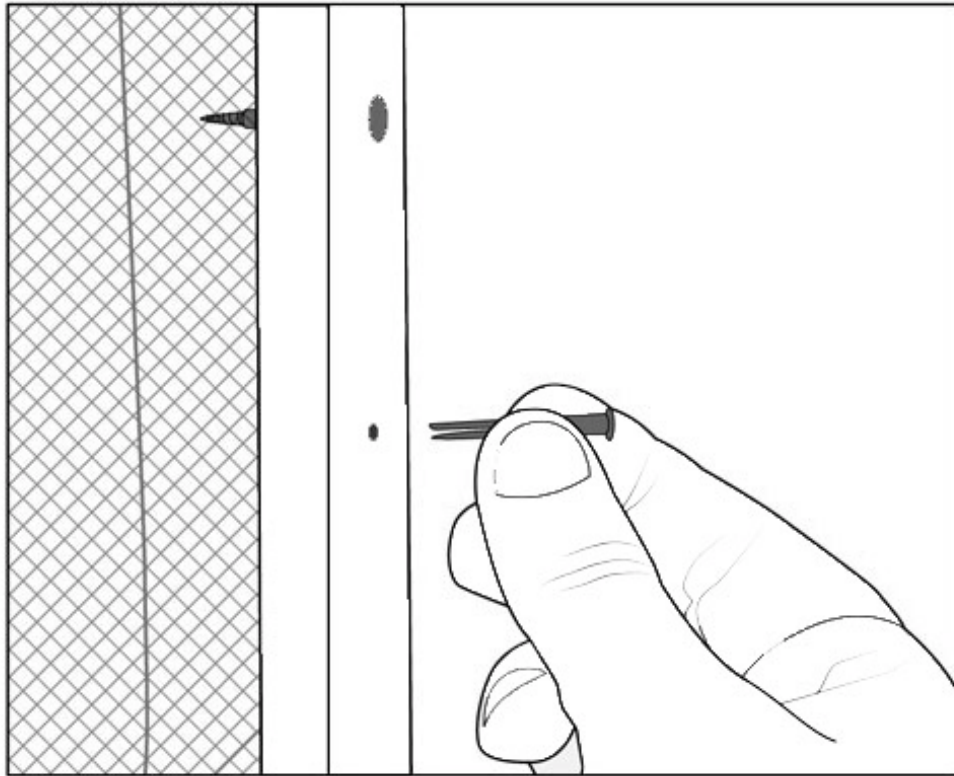

- Fasten the foundation with support pins.
- The pins go through the two predrilled holes on each of the side bars and clip the foundation in place. You use two pins on each side bar (four pins per frame). Simply insert them by hand.

The Inner Cover

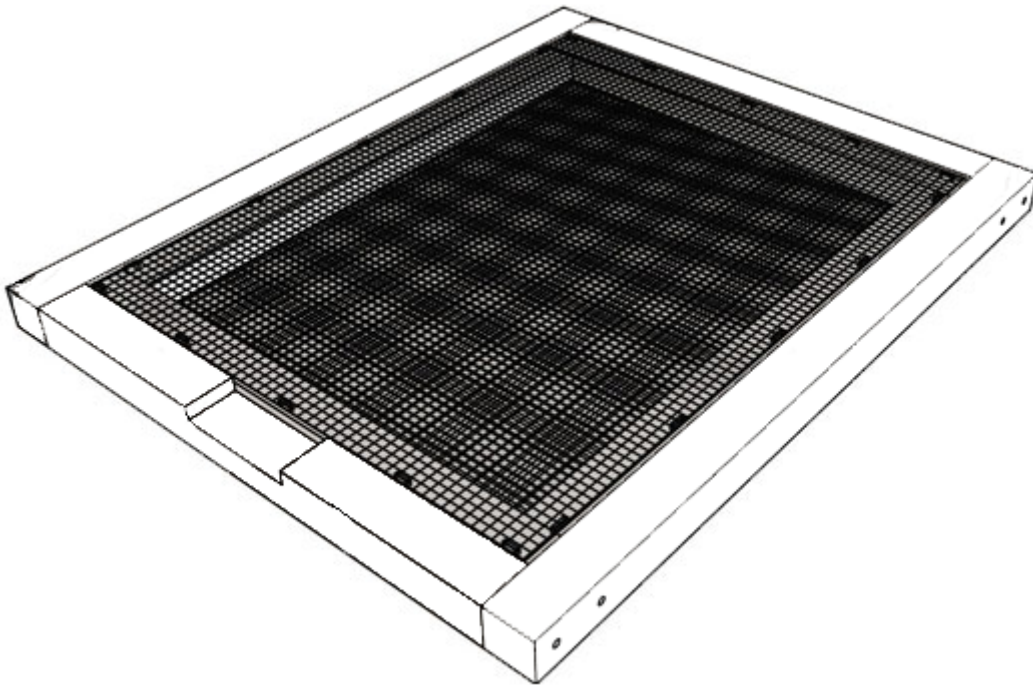

Building an inner cover is as easy as building a wooden frame. Shouldn't cost more than \$15, and next to nothing when using recycled pieces.

A double screened inner cover is the best option for your hive. It is sturdier and it allows you to have an extra upper entrance in the

hive, on one side of the cover. The other side has no entrance, so you can have it either way according to bees' activity and season.

Size: 19-7/8 inches x 16-1/4 inches x 1-1/8 inches (ten-frame hive)

Pine is easy to find and also cheap. You can use either knotty or clear, the choice is yours. Clear pine is smoother and easier to cut, while knotty pine is a little bit cheaper.

Lumber	Hardware	Fasteners
1, 6' length of 5/4" x 3" clear or knotty pine lumber	24" of 1/8" hardware cloth. (#8 typically comes in 3' wide rolls, but some beekeeping supply stores sell it by the foot.)	10, #6 x 2-1/2" deck screws, galvanized, #2 Phillips drive, flat-head with coarse thread and sharp point
	Optional: weatherproof wood glue	40, 3/8" staples for use in a heavy-duty staple gun

Double-Screened Inner Cover for the Ten-Frame Langstroth Hive			
Quantity	Material	Dimensions	Notes
2	5/4" x 3" clear pine	19-7/8" x 2- 1/4" x 1-1/8"	These are the long rails. Rabbit <i>both</i> sides of the inside edge 1" wide by 1/8" deep. This cut will accommodate the thickness of the hardware cloth. Cut a 2-1/4" x 1" notch at both ends of the long rails.
2	5/4" x 3" clear pine	13-3/4" x 2- 1/4" x 1-1/8"	These are the short rails. Rabbit <i>both</i> sides of the inside edge 1" wide by 1/8" deep. This cut will accommodate the thickness of the hardware cloth. Cut a 3" x 1-1/4" x 3/8" entrance notch centered along the edge of <i>one</i> of the short rails. This is most easily done with a chisel or a router if you have one.
2	#8 hardware cloth	17-1/4" x 13- 1/2"	This is the screened top and bottom.

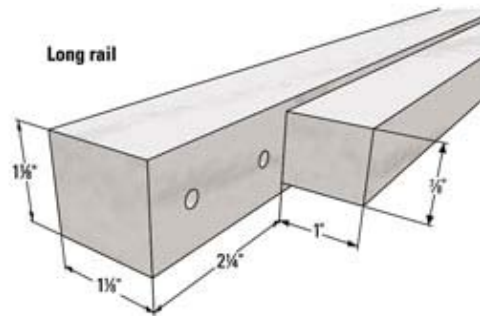
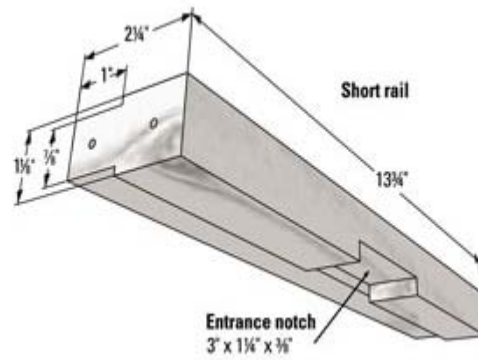
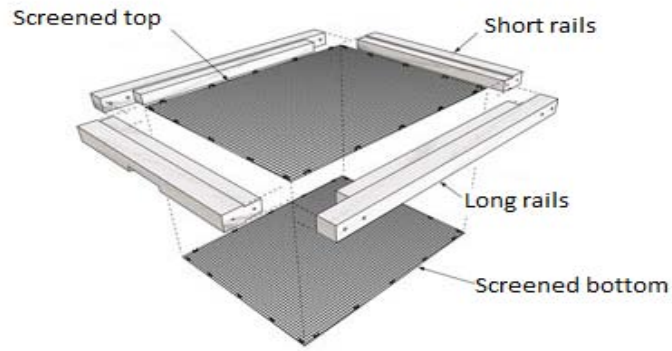

Double-Screened Inner Cover for the Eight-Frame Langstroth Hive			
Quantity	Material	Dimensions	Notes
2	5/4" x 3" clear pine	19-7/8" x 2-1/4" x 1-1/8"	These are the long rails. Rabbit <i>both</i> sides of the inside edge 1" wide by 1/8" deep. This cut will accommodate the thickness of the hardware cloth. Cut a 2-1/4" x 1" notch at both ends of the long rails.
2	5/4" x 3" clear pine	11-1/4" x 2-1/4" x 1-1/8"	These are the short rails. Rabbit both sides of the inside edge 1" wide by 1/8" deep. This cut will accommodate the thickness of the hardware cloth. Cut a 3" x 1-1/4" x 3/8" entrance notch centered along the edge of <i>one</i> of the short rails. This is most easily done with a chisel or a router if you have one.
2	#8 hardware cloth	11" x 17-1/4"	This is the screened top and bottom.

Double-Screened Inner Cover for the Nuc Hive			
Quantity	Material	Dimensions	Notes
2	5/4" x 3" clear pine	19-7/8" x 2-1/4" x 1-1/8"	These are the long rails. Rabbit <i>both</i> sides of the inside edge 1" wide by 1/8" deep. This

			cut will accommodate the thickness of the hardware cloth. Cut a 2-1/4" x 1" notch at both ends of the long rails.
2	5/4" x 3" clear pine	6-1/2" x 2-1/4" x 1-1/8"	These are the short rails. Rabbet <i>both</i> sides of the inside edge 1" wide by 1/8" deep. This cut will accommodate the thickness of the hardware cloth. Cut a 3" x 1-1/4" x 3/8" entrance notch centered along the edge of <i>one</i> of the short rails. This is most easily done with a chisel or a router if you have one.
2	#8 hardware cloth	6-1/4" x 17-1/4"	This is the screened top and bottom.

Double-Screened Inner Cover for the British National Hive

Quantity	Material	Dimensions	Notes
2	5/4" x 3" clear pine	18-1/8" x 2-1/4" x 1-1/8"	These are the long rails. Rabbet <i>both</i> sides of the inside edge 1" wide by 1/8" deep. This cut will accommodate the thickness of the hardware cloth. Cut a 2-1/4" x 1" notch at both ends of the long rails.
2	5/4" x 3"	15-5/8" x 2-	These are the short rails.

	clear pine	1/4" x 1-1/8"	Rabbet <i>both</i> sides of the inside edge 1" wide by 1/8" deep. This cut will accommodate the thickness of the hardware cloth. Cut a 3" x 1-1/4" x 3/8" entrance notch centered along the edge of <i>one</i> of the short rails. This is most easily done with a chisel or a router if you have one.
2	#8 hardware cloth	15-1/2" x 15-1/2"	This is the screened top and bottom.

- Align the short rails with the notches on the ends of the long rails.
- Insert one deck screw halfway into each corner of each long rail. Drive the screws through the long rails and into the short rails. Center each screw top to bottom and place it about half an inch from the outside edge of the assembly. Only drive the screws all the way in after you've checked if everything fits together as it should. Now you can add one extra screw in each

corner of the frame, about one inch apart from the original ones.

- If you want to use glue, choose a weatherproof one. It adds strength to the cover and this will prove useful if you live in harsh winter areas.
- Now you can attach the screening material and place the cover on the hive.
- Attach the #8 hardware cloth to the "opening" of the frame (on both sides). The screening should fit into the 1/8 inch deep rabbet cut. Use 3/8 inch staples with 2 inches in between them all around the screening perimeter. Make sure you leave no space for the bees to squeeze through. Do not paint the inner cover. Leave it natural and unpolished, as with all the internal parts of any beehive. Remember, paint is toxic for the bees!

- When you want your bees to be able to exit the hive through the upper side, put the inner cover with the notch facing down.

To block their exit, reverse the cover as depicted below:

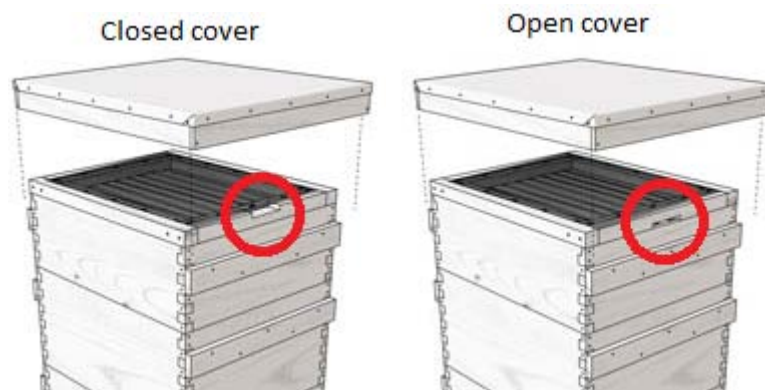

The Telescopic Outer Cover

Quantity	Material	Dimensions	Notes
2	1" x 12" clear pine	21-1/4" x 2-1/4" x 3/4"	These are the long rails. Rabbet 3/4" wide by 3/8" deep along entire length of top edge.
2	1" x 12" clear pine	18-1/4" x 2-1/4" x 3/4"	These are the short rails. Rabbet 3/4" wide by 3/8" deep along entire length of top

			edge. Also rabbet 3/4" wide by 3/8" deep along both ends of the boards.
1	3/4" exterior plywood	21-1/4" x 17-1/2" x 3/4"	This is the top.
1	20" aluminum flashing	23-3/4" x 20"	This is the protective metal roof. Wrap the flashing over the top of the assembled outer cover. There will be a 7/8" lip folded over the edges of the top. Fold the corners to avoid sharp edges.

- Fit the plywood into the rabbeted grooves of the long rails. Fit the short rails onto the board.
- For the outer cover assembly, have an object act as a stopper so you can push the frame against it. Put one end of the cover on the workspace against the stopper. Insert two deck screws in each corner of the short rails. Turn the cover end for end and insert screws in the other corners of the short rails as well.

- Secure the plywood and the assembly together with five evenly spaced deck screws along each of the long rails and into the edges.
- Fit the aluminum flashing tight and evenly on the outer cover, bending the flashing down over the edges of the frame, thus creating a 7/8 metal sheen covering the sides of the top edge. Bend it around the corners. If it's the case, use a light hammer to flatten and tighten them around. Be careful not to cut yourself, as the aluminum edges are sharp.
- Finally, screw the folded aluminum edges in place with the #8 x 1/2 inch lath screws.

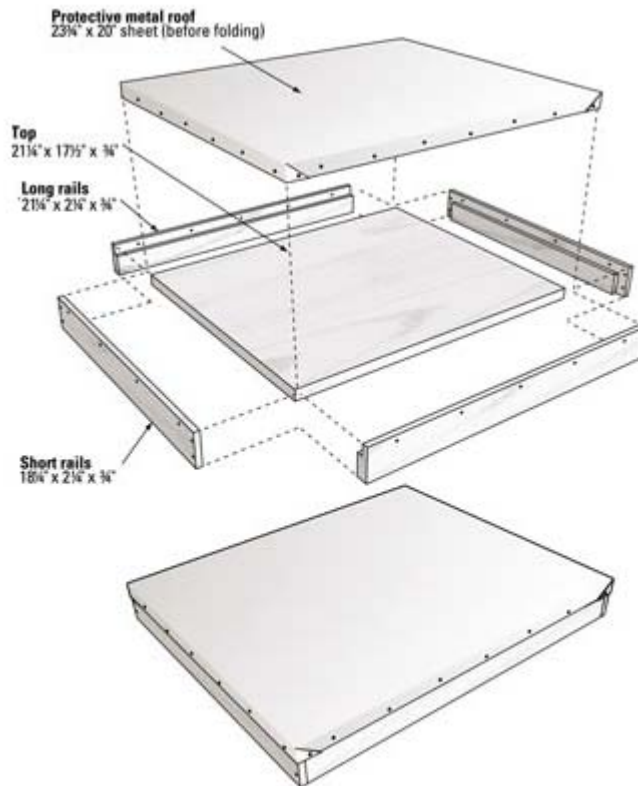

Assembling the Hive

Start with the bottom board on the ground, or on a stand, if you have one. Make sure the ground or floor is flat. On top of the bottom board come the hive bodies, one over the other. If you have a queen excluder, now is the time to put it between the first and the second hive bodies. I prefer to keep my queen away from the honey storages, as her eggs encourage the workers to bring pollen and

spoil the honey. Insert the frames with foundation into the hive bodies. Whenever your hive body is half full with combs and capped honey, you need to build another one.

The inner cover comes next, right over the last super, and over it comes the outer telescopic cover. Now it's time to bring your bee family into its new home.



Adding Feeders to your Hive

It sometimes happens that bees don't have enough honey to survive the winter. If there's a miscalculation, it's most probably the beekeeper's. The bees rely on the honey you take away as well when they store provisions. Luckily, they can survive on sugar water in times of need. Feeders are instruments designed to offer food to your bee family when their nectar is running low. It's also an accessible way to give them medicine, if it's the case, by dissolving it in the syrup. There are several kinds of bee feeders, and we also present a way in which you can build one yourself.

Entrance Feeder



This feeder, also known as "Boardman feeder", consists of a jar of syrup turned upside down, its mouth attached to a box that matches into the hive entrance. They are easy to use and inexpensive, but not as practical and effective as the top feeder. It can attract bees from other hives or other robbers and medication is impossible because it sits right in the sunlight, which spoils the syrup as well. Refills must be done every day and during spring the cluster is at the top of the hive, out of the feeder's reach. There is also the risk of being stung when applying it.

Pail Feeder



This is a plastic pail with the capacity of a gallon. It has a closure on top with little holes in it. The pail contains the syrup and the top is fastened in place. Then it is placed in the hole in the inner cover. It can also be placed in an empty top super, right beneath the outer cover. Refilling it is not practical, requiring you to smoke the bees, though its high capacity will only demand it weekly. However, unlike the hive-top feeder, only a few bees can feed at a time, because of the narrow access area to the syrup.

Frame Feeder



This feeder is basically a plastic frame that replaces one of the regular hive frames in the top super. However, it is not that practical because of its reduced capacity; also, it exposes to stings and bees can drown in it. Not to mention you're one frame short.

Bag Feeder



The bag feeder, as the name says, is just a bag, preferably with the capacity of one gallon, filled with sugar syrup and laid on top of the inner cover. With a razor blade cut a few holes in the air bubble that

forms on top. It has the price advantage and is very accessible by the bees. It also prevents their accidental drowning.

Hive-Top Feeder

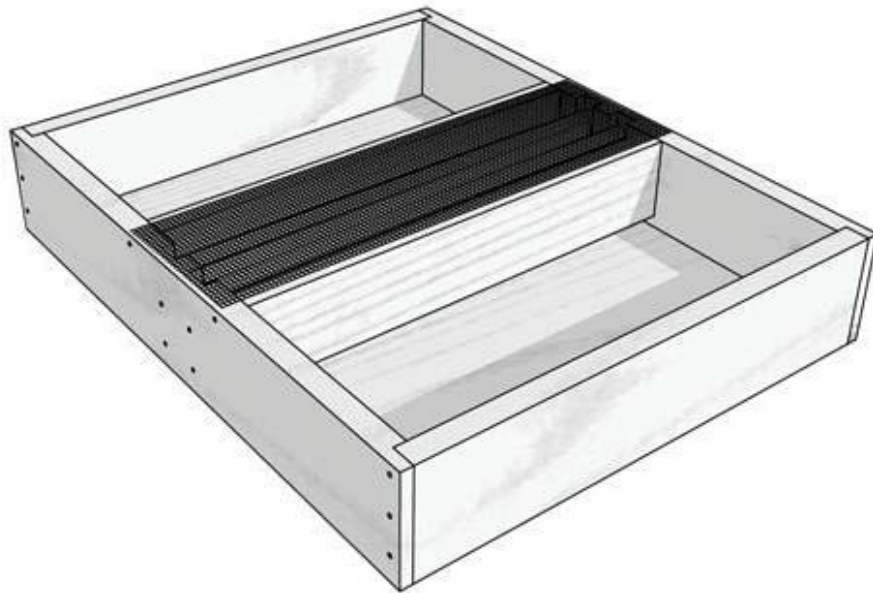

The hive top feeder replaces the inner cover, making it very easy to use and accessible. It has a container that can store up to three gallons of liquid. Its floor is screened to facilitate the access of the bees from below.

Advantages:

- You only need to fill it weekly, or even once in two weeks;
- It's easy to refill without exposing you to stings;
- There is no disturbance in the hive (smoke actually slows down their activity);
- Medication added is not exposed to sunlight.

How to Build Your Own Hive-Top Feeder

Since I consider the hive top feeder the most efficient in its branch, why not teach you how to make one? Its construction is similar to the covers, so you should be familiar with it already. Its cost revolves around \$50.

Size: 19-7/8 inches x 16-1/4 inches x 3-1/2 inches (for a feeder to fit a ten-frame Langstroth-style hive).

Lumber	Hardware	Fasteners
1, 12' length of 1" x 4" clear pine lumber	Optional: weatherproof wood glue	28, 6 x 1-3/8" deck screws, galvanized, #2 Phillips drive, flat-head with coarse thread and sharp point
1, 2' x 4' sheet of 1/4" lauan plywood	A pint of exterior polyurethane or marine varnish	12, 5/32" x 1-1/8" flat-head, diamond-point wire nails
	A tube of silicone caulking (as used for fish aquariums) or melted beeswax	3/8" staples for use in a heavy-duty staple gun
	1/8" hardware cloth (typically comes in 3' x 10' rolls, but some beekeeping supply vendors sell #8 hardware cloth by the foot; you only need a couple of feet for this project)	

Feeder for a Ten-Frame Langstroth Hive			
Quantity	Material	Dimensions	Notes
2	1" x 4" clear pine	19-7/8" x 3-1/2" x 3/4"	These are the long side boards of the feeder. Cut a 1/4" wide by 3/8" deep dado along the entire length of

			<p>the side boards, 1/2" from the bottom edge.</p> <p>Dado two channels 3/4" wide by 3/8" deep along the long dimension of the side boards. Space the dado cuts 3/4" apart at the center mark of the side boards.</p> <p>Rabbet 3/4" wide by 3/8" deep along both ends of the boards.</p>
2	1" x 4" clear pine	15-1/2" x 3-1/2" x 3/4"	<p>These are the short side boards of the feeder.</p> <p>Cut a 1/4" wide by 3/8" deep dado along the entire length of the side boards, 1/2" from the bottom edge.</p>
2	1" x 4" clear pine	15-1/2" x 2-1/2" x 3/4"	These are the shallow entrance walls to the feeding area.
2	1" x 4" clear pine	14-3/4" x 2-5/8" x 3/4"	These are the deep entrance walls in the feeding area.
2	1/4" lauan plywood	15-1/2" x 9-1/4" x 1/4"	This becomes the "floor" of the feeder.
2	#8 hardware cloth	14-3/4" x 5"	These are the screened inserts for the feeding area. Fold each in half the long way, making a V

			shape that is 14-3/4" long by 2-1/2" wide.
1	#8 hardware cloth	16-1/4" x 5"	This is the screened top for the feeding area.

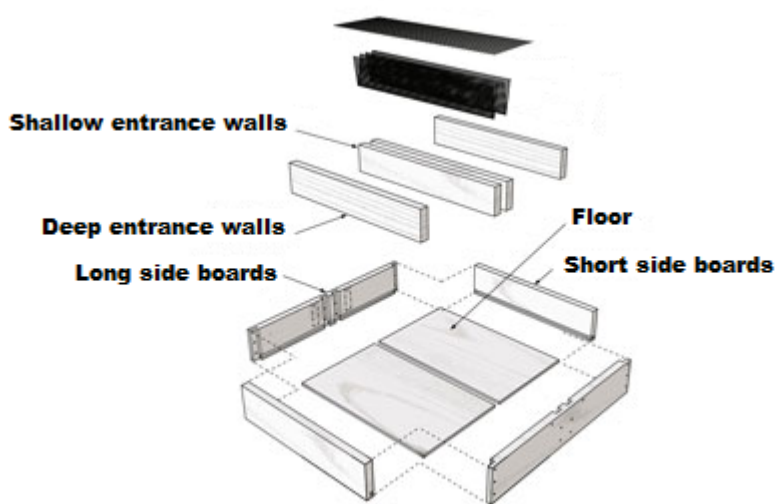

- Attach the short sides to the feeder floor.
- Insert the pieces of the plywood floor into the side boards' dado grooves. Same goes for the long sides. Attach the rabbet edge of the long boards to the short side boards, making sure the dado grooves are securing the plywood floor edges.

- Now tap the shallow entrance walls into the dado cuts in the center of the long boards with a hammer.
- Put the assembly on the work surface and have the long side against a stopper. Screw the corners of the long boards and the edges of the short boards together. Turn the assembly end for end and do the same for the other corners.
- Screw together the shallow entrance walls and the long side walls. Eight screws should do - two in each wall.
- Turn the assembly upside down and nail the plywood edges to the shallow entrance walls. Eight wire nails per wall is good.
- Applying glue is optional. Marine varnish or polyurethane on the feeder would make it watertight. It is good to apply two coats. Make sure you let the first one dry before applying the second one. Do the same with the deep entrance walls. Let the second layer dry overnight.

- Apply silicone to every interior seam where the liquid might run through.
- Attach the deep entrance walls to the feeder.
- Now you can attach the entrance walls by hammering them 3/4 inch from the shallow entrance walls. It should be flush with the top, leaving a gap between the bottom of the deep walls and the assembly floor, through which the liquid gets into the feeding area.

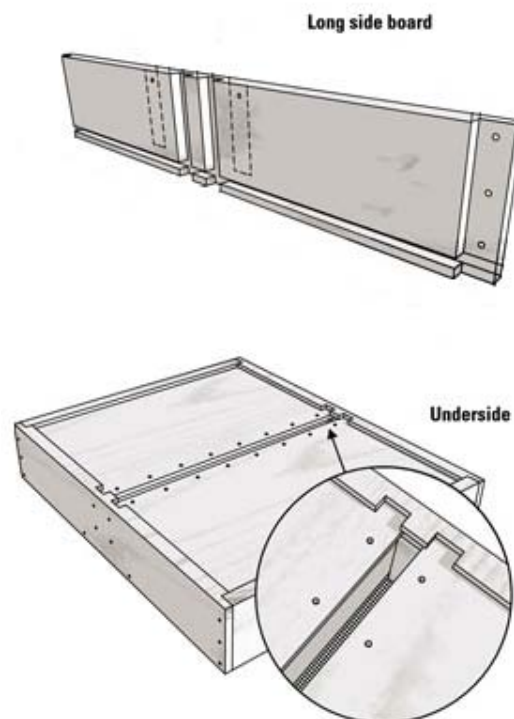

- Screw the deep wall edges and the long side boards together. Six screws is enough.
- Insert the two hardware cloths between the shallow and deep entrance walls with the V facing forward. No need to fasten them, as they sit in place due to the pressure.
- Add the 16-1/4 x 5 inches hardware cloth on top of the feeder assembly area, in the center. Staple it down, making sure the bees can't squeeze through. Don't use more than ten staples, as you might want to remove them for cleaning. Ten is enough.
- To use the feeder, simply fill it with syrup and put it in the inner cover's place, with the outer cover on top.

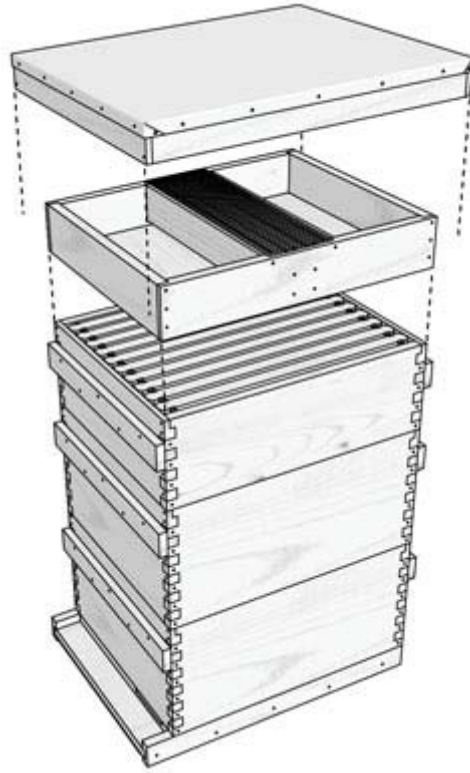

VII. Getting Started



You should act ahead of time. Order the bees and the materials since winter. Everything should be ready until April, when the bees awake from their numbness. Drones emerge in spring but they are banished when fall begins. During summer there are about 1000 drones in a hive. Don't harvest the honey too late in fall, or the bees risk starvation over winter.

Of course, if you live in areas where you enjoy a warm climate all the time, you can discard the above information. Your activity as a beekeeper is even easier and you will need even less equipment. Bees won't be facing winter and they will work all year long. You don't need to worry about feeders and there is more honey for you.

Installing the Bees

If the package is being mailed to you, you should let the post office workers know what you are expecting and ask them to keep the package in a cool and dark place if they have one. They will most likely want to get rid of the bees as soon as possible and will call you to get it.



It goes without saying that everything should be ready when the bees arrive. Inspect the package thoroughly and make sure the bees are alright. Some inevitably may die, but the swarm should be well and kicking. If the casualties match up more than an inch you should have your bees replaced. Do not transport the bees in the trunk. They haven't been in their environment for some time already and they don't need

more of that ordeal. At home, put the package in a cool dark place and leave it for about an hour. Spray it with cool water. After the cooling hour spray the package with sugar water. It is a good idea to have a feeder prepared.

It is best to put the bees in the hive in the afternoon of a nice day. If it's raining or it's windy you should wait until the next day. Don't forget to put your suit on. Follow these steps to transfer your bees into the hive:

- Spray the bees with sugar syrup half an hour before hiving them. Do it thoroughly, but be careful not to drown them.
- Pry open the package with the hive tool. Take out the nails and shake the package a bit so the bees fall onto the bottom. Don't worry, they won't be hurt.
- Remove the syrup can and the queen cage from the package and put the cover back on (without the nails). In the queen

cage you should see the queen and a few worker bees. If the queen is dead, call the supplier and ask for a replacement. It should be free of charge. Until it arrives, you can continue accommodating your colony. They will be fine.

- Next, gently slide away the metal lid. Remove the cork and look for the candy inside. If it's there, remove the disc lid. If it's not there, you can put a marshmallow instead to plug the hole
- Bend two nails at ninety degree angles and make a hanging bracket for the queen cage.
- Remove five frames from the brood chamber.
- Spray the package again and shake it. Hang the queen cage with the candy side upwards between the centermost frame and the next one facing the center. The cage's screen side must face the hive center.
- Spray the bees again and shake it one more time. Remove the cover and pour (shake if needed) half of the bees right above

the queen cage. Pour the rest in the area where you removed the five frames. After they move around, put four of the removed frames back in. Be careful not to kill any. If they pile up one over another, gently spread them around with your (gloved) hand.

- If you have a hive-top feeder, put it on. If you use a pail feeder, put the inner cover on and insert the feeder in the hole. Wrap a paper around it for insulation and then add one more super.
- Until the bees get used to their new home, you should close the ventilation hole in the inner cover.
- Put the outer cover on top.

You're done!



Opening the Hive

- Whenever you want to open your beehive approach it from behind or the sides. Avoid crossing your ways with the bees. For that you need to also take notice of the direction they're heading: normally they fly out in a straight line, but if they go sideways, change your direction and approach the hive from the opposite side. W
- When you get about 3 feet away from the hive start puffing the smoker into the entrance of the hive. Don't overdo it. Four times should be enough. You wouldn't want to choke your bees to death, just let them know you're there.



- While still at the side start lifting one edge of the outer cover and puff a few more smokes inside. Slowly let the cover back in place and wait about half a minute.



- Put the smoker down and remove the cover with both your hands, slowly. Leave it upside down on the ground (metal touching the ground).

- If you have a top-feeder in place, you need to remove that as well. If not, skip to the next step.
- Pick up the smoker again and puff through the screened access into the hive.
- Start prying the feeder away from the body. If stuck, use a tool. Avoid sudden moves and noises. Through the crack puff the bees some more. After 30 seconds remove the feeder completely. Lay the feeder with one side on the outer cover, and one other side on the ground, thus avoiding crushing any bees that may have remained on it.





Removing the Inner Cover of Your Beehive

If you don't have a feeder in the hive, you have an inner cover. This is similar to removing the feeder.

- Blow some smoke puffs through the cover hole.
- With the flat end of the hive tool, slowly release the inner cover from the super.

- Loosen two sides one by one until you can lift it up like a trap door. Blow smoke again. After 30 seconds remove the cover completely. Leave it on the outer cover with one side on the ground and another on the cover in order to avoid crushing any bees left on it.



Cleaning the Hive

This section goes through the steps of the basic spring cleaning.



- Start by smoking the bees. Remove the parts that you want to clean with clean parts filled with fresh wax.
- With a scrubbing brush moistened in hot water clean the parts of leftovers and wax. Make sure you do this away from the hives, so the bees won't be attracted by the honey smell.
- Fill a bucket with hot water and dissolve two cups of bleach in it. Soak the hive parts for 15 minutes and then brush them

again. Refresh the water when it becomes dirty and wash one last time.

Controlling the Swarm



Swarming is the start of a new colony by the queen and a few workers from another colony. It is a natural action of the bee colony and it occurs either when the hive has no more place for the bees to expand their wax combs or when they

feel the need to reproduce. Although natural, the act of swarming is considered unproductive, because you lose bees.

However, new swarms expand very quickly, so if you manage to catch and control the new swarm, you are in for a lot of honey. For this case, you need to let the bees swarm but closely watch them. When the queen leaves the hive with the workers, they will first settle close by on a tree branch and send a few workers to scout ahead. This is the time to catch the swarm with special instruments called nucs. This is risky however. You might not see them and you may lose the swarm and consequently the hive, if there are after swarms. Most beekeepers are trying to prevent the swarming.

Here is how you prevent a swarm:

- Add supers when needed. Don't give your bees reasons to look for home elsewhere.
- Clear the honey clogs in the brood chamber or replace the frames to ensure the queen has space to lay eggs.
- If there is too much traffic around the brood chamber, have a top entrance on your hive.

- Checker boarding is the practice of mixing full waxed and capped frames with half capped frames and empty frames to drive off the bees' sense of having too much honey, which triggers swarming.
- Clipping one wing of the queen, rendering it unable to fly.

VIII. The Beekeeper's Seasonal Activities

Spring Activities

Every spring the beekeeper has the same routine. Every hive must be inspected to see if the queen is still alive and is still able to lay eggs. Hives must be inspected thoroughly to see if they hide possible diseases but also to ensure that the bees have enough food until their first honey production. Even if they seem healthy, you can give them certain treatments to prevent diseases. Purists, however, sustain that these substances alter the taste of honey. Some beekeepers choose to let bees swarm and cleanse themselves, even

at the risk of losing many families. My advice is to use medication only if you have problems with diseases. Usually, if you keep the basic rules of hygiene and



environment, your bees should handle themselves fine. But that choice is entirely up to you and your style of beekeeping.

When bees cover seven of the ten frames from the upper level, it is time to add a new one. If you medicate your bees, you need to stop the administration two weeks prior to harvest, to make sure the medicine won't alter the purity of honey.

Summer Activities

Come July, if your bee family is diligent, you should add one more level to the hive. Bees need wide spaces, otherwise they will stop working, or, worse, they will swarm, meaning they will find another

home and start a new family.

Continue monitoring the hives. Monitor them and the queens and simply add a new level every time the center frames in the existing levels become full.

Make sure the hive is drafty. Don't panic when you see a cluster of bees bulking at the entrance of the hive. They are simply cooling off. This means only that inside the hive the temperature is probably too high for them and you should air it better by drilling additional holes in the box.

Be careful for thieves! Wasps and other species of bees don't have the same admirable way of making a living. Their more feral cousins tend to raid the honey. You wouldn't want your hives to be under

siege.



At the end of the summer the queen's rate of laying eggs drops. This is only normal, as the cold is coming. The drones may still be there, but the bees are fewer and the activity is reduced, as the flowers wither. Bees become uneasy and more protective with their honey.

Collect the honey. Summertime is the time when honey is being harvested. If you collect it when fall is close, you risk starving your bees over winter.

Fall Activities

As days get shorter and weather gets colder, the pollen resources run scarce. In this period the hive population drops. The queen lays fewer and fewer eggs and the drones leave the hive. Now the bees create propolis, which is used to patch the hive. The bee family gets ready for the winter, and you should help.



In mid-September you should make sure they have enough honey (they usually do), and if not provide for them; beekeepers compensate for honey they take with sugar water syrup. Be extra

vigil about raiders in this period.



Check every hive and make sure they all have queens. The easiest way is to look for eggs inside. If there

are eggs, it is obvious that the hive has a queen. Be careful not to make the common confusion between eggs and larvae. Eggs show that the queen has been there in the last two days, while larvae can be as old as eight days, and for bees, eight days is a long time. So if you see larvae, it doesn't necessarily mean that the queen is present or alive. Always look for eggs!



Egg



Larvae



Eggs and Larvae

Make sure the bees are healthy. If you apply medication, this is the time to do it.

Make sure the hives are well ventilated. During winter the temperature inside the hive is pretty high. If the ventilation is poor, the heat generated by the bees' body elevates and when it meets the

cold surface of the walls it creates condensation. Cold drops of water (and sometimes even iced water) fall onto the bees, which if does not kill them it surely gets them cold and eventually will lead to their death.

Winter Activities

Keep the hive exit under observation and keep it clear of snow and dead bees.

Make sure the bees have enough food. There are great chances that bees deplete their reserves during winter and die of starvation.

At the end of winter, in a warm day, take a look inside the hive. Don't move any frame, just look for huddled bees inside in the upper section. If there is no trace of capped honey cells, you should start

feeding them artificially. However, once you start this, you cannot cease doing so until they start gathering nectar.

Clean and repair your equipment.

You can also start additional activities or hobbies that go hand in hand with beekeeping and can also help you:

- mead



or

- candle production



VIII. FAQ

Q: Will bees influence my plants?

A: Yes, the bees pollinate the plants in your garden, assuring thus a better and richer harvest.

Q: Will bees bother my neighbors?

A: Most likely. Make sure they are not in the proximity of roads,

gates or other households.

Q: Is beekeeping time-consuming?

A: No. It is only necessary to look inside the hive once a week during summer. During winter you can look just once a month to make sure the bees have enough nourishment, and this is not really necessary.

However, watching the bees work has psychological therapeutic effects.

Q: How do I harvest the honey?

A: First of all the bees must be removed from the frames, usually with a soft brush or with a smoker. Then the frame is removed, uncapped and introduced inside the centrifuge, the device that spins the frames for the honey to pour out of them. After that, it must be rinsed, left to mature and then put in jars.

IX. Benefits of Beekeeping

1. Beekeeping can be done by anyone: men, women, old and young.
2. It is not necessary to own a land. Even if you live in a flat, you can have a hive or two on the roof as long as your neighbors agree. If you share some honey they might help you in that sense.
3. It does not require a lot of time.
4. The gear is not expensive.
5. You don't have to spend a lot. You only need the suit and a few hives.
6. Bees help with the pollination of plants.
7. Beekeeping boosts your self-esteem and allows you to make profit.
8. Honey doesn't need special storage conditions. It doesn't go bad.
9. Honey and its adjacent products have extraordinary healing properties.

10. Most honey products can be used as food, medicine or supplement.

